

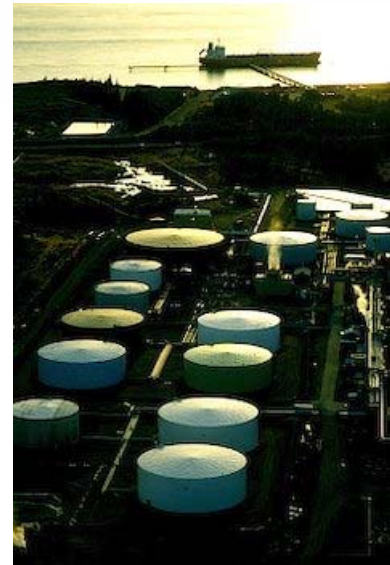

TECHNICS

Production Fluids & Test Automation
Designers/Builders of Fluid Systems & Laboratories



LOGOS

Integration Services

**Tank Farm &
Blending Process
Management Systems**



Tank Farm Management

The Tank Farm Module works as a stand alone or integral interface with the blending process system. Information on the tank geometry & alarm setpoints and the material properties of its content are retrieved from the database and presented to operators and supervisors.

- Communicates with a wide variety of databases including SAP, Access, Oracle, and Excel.
- An array configuration allows new tanks to be easily added.
- Inventory reports can be generated daily, weekly, or monthly at a selectable time of day.
- Works with any tank geometry.
- API Temperature compensated volume.
- Works with pressure type level transmitters.
- Tank Name and material properties can be adjusted in the database in real time.
- Alarm notification and logging
- Manual Pump Control
- Read and write serially to motor drives.
- Retains Pump Data like hours of operation and faults.

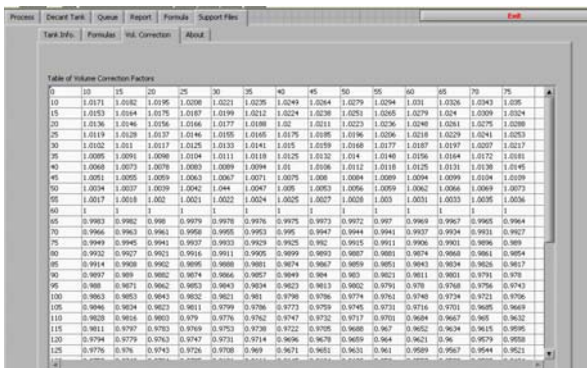
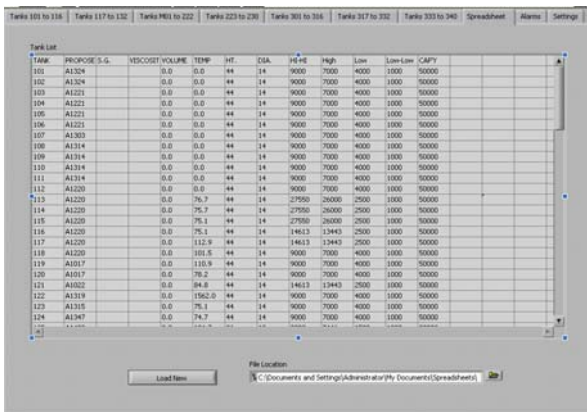
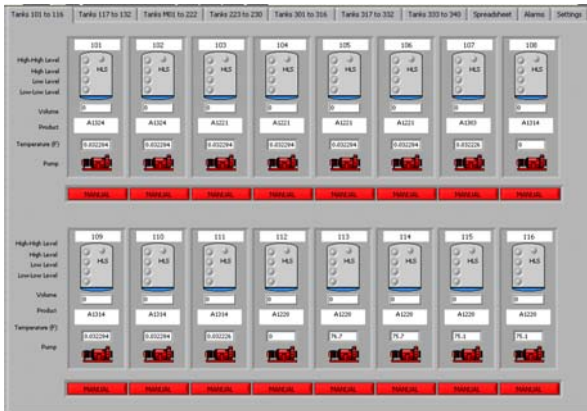

Typical Scope of Work

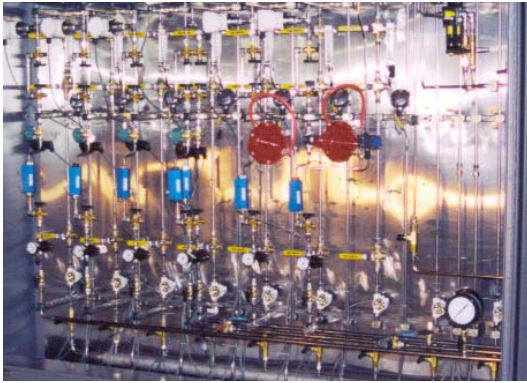

Sub-System Fabrication

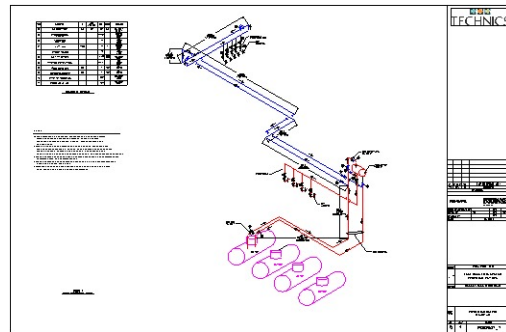
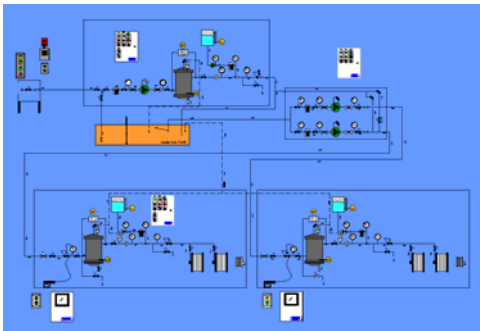

Process & Field Design



Contact Technics

Sales: (630) 215-3742

Email: info@technicsglobal.com

Visit: www.technicsglobal.com

**Controls Design
& Fabrication**

